

## Drive Shaft

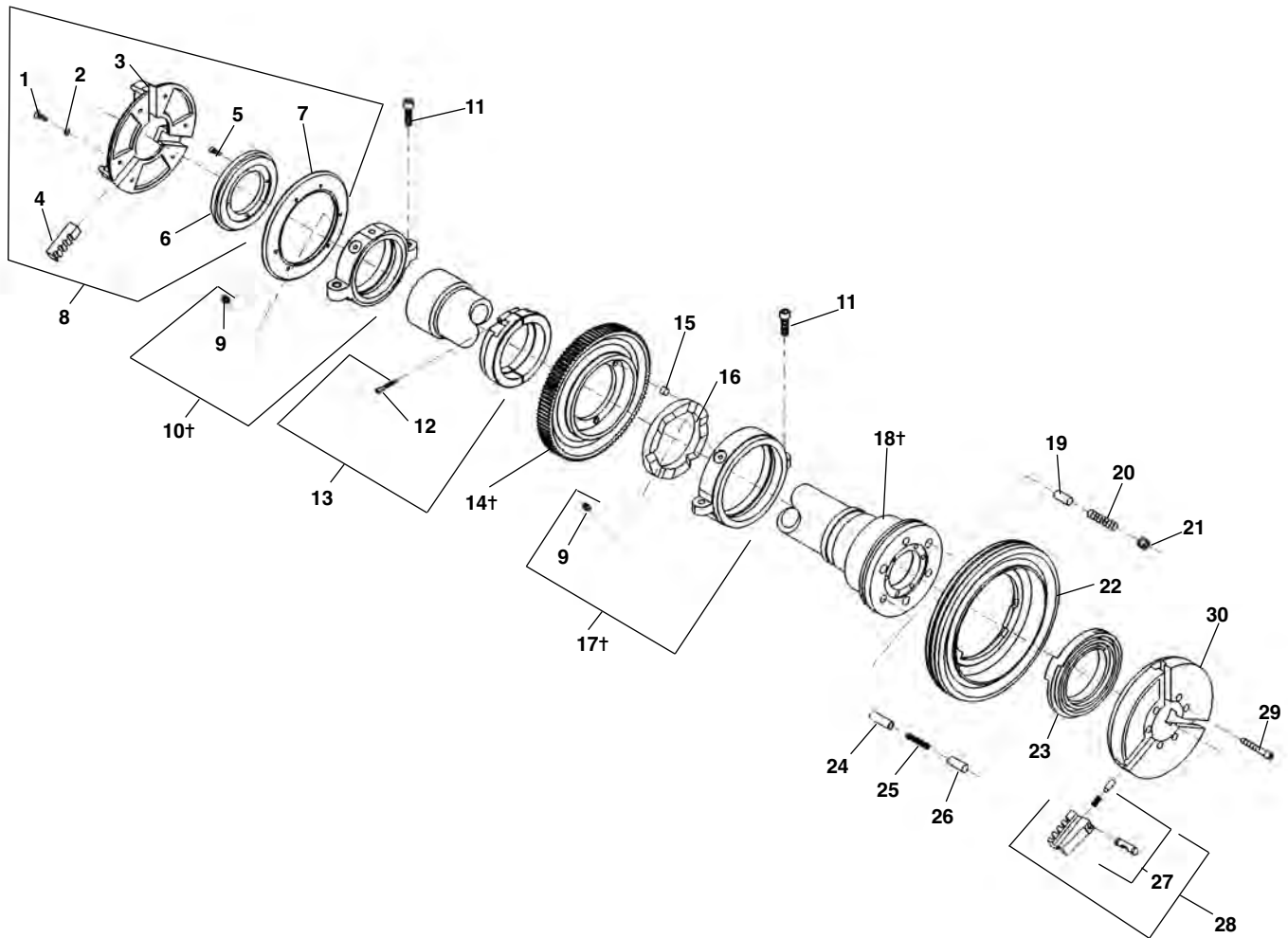

**NOTE: Order parts by Catalog Number only.  
DO NOT order by Reference Number.**

Ref. No.	Catalog No.	Description	Ref. No.	Catalog No.	Description
—	47585	Drive Shaft Assembly	15	44490	Drive Plug (3)
1	46790	Screw (6)	16	43895	Pressure Plate
2	40270	Lock Washer (6)	17†	43455	Front Bearing Assembly
3	43735	Centering Head	18†	43105	Drive Shaft
	19346	Centering Head (Europe)	19	44320	Pressure Plunger (3)
4	46500	Centering Jaw Set	20	44325	Pressure Spring (3)
5	46765	Screw 10 – 32 x 1/2"	21	44330	Pressure Set Screw (3)
6	43750	Scroll	22	43420	Handwheel
7	43740	Back Plate	23	43450	Scroll
	19356	Back Plate (Europe)	24	44315	Drive Wedge
8	47570	Centering Head Assembly	25	44310	Drive Spring
9	46860	Grease Fitting	26	44305	Drive Cap
10†	41338	Rear Bearing Assembly	27	44715	Jaw Insert Set
11	46745	Screw 3/8" – 16 x 1 1/4" (4)		97365	Jaw Insert Set f/Plas. Coated Pipe
12	90255	Screw 10 – 32 x 1 1/4"	28	43900	Chuck Jaw Set
13	83525	Split Ring Assembly	29	45160	Screw 7/16" – 18 x 2" (6)
14†	43460	Drive Gear	30	43440	Chuck Cap

† Service Notes: Ref. Nos. 14 & 18 - When installing gear on shaft, align "O" mark on front of gear with "O" mark on the rear of the drive shaft flange.

Ref. Nos. 11 & 17 - When replacing the front or rear bearing brackets, position grease fittings toward the operator's side of the machine.